

TECHNICAL INSTALLATION & WIRING MANUAL

Jasmine Hybrid Smart Switch (4-Channel System) Model: JSH-HSW-01-N

Document Revision: 2.1.0

1. SAFETY & REGULATORY COMPLIANCE

1.1 Hazard Classification Definitions

This manual contains critical safety classifications. Adhere strictly to all warnings and safety instructions to prevent property damage, personal injury, or death.

DANGER: RISK OF ELECTROCUTION

HIGH VOLTAGE HAZARD. This device must be installed in accordance with national and local electrical codes (e.g., National Electrical Code/NEC, CEC).

- **Turn off** the main power supply at the circuit breaker or fuse box before beginning installation or maintenance.
- Always use a reliable, non-contact voltage detector to verify that the power is completely off before touching any conductors.
- Do not handle wiring with wet hands or while standing on damp surfaces.

WARNING: SYSTEM LIMITATIONS

- Do not exceed the maximum load rating of **10A** total (or as rated per channel) for the system. Overloading may cause permanent hardware failure, fire, or damage to surrounding structures.
- This device is designed strictly for **dry indoor residential and commercial environments**. Do not expose it to moisture, rain, high humidity, or chemical agents.

2. TECHNICAL SPECIFICATIONS

Parameter	Specification Value
Model Number	JSH-HSW-01-N
Input Voltage	230V AC \pm 10%
Input Frequency	50Hz / 60Hz
Maximum Total Current	10A (Resistive)
Control Channels	4 Independent Channels
Internal Topology	Low-voltage control loop with relay-driven smart hybrid interface
Wiring Terminal Capacity	1.5 mm ² to 2.5 mm ² (16 to 14 AWG)

3. SYSTEM ARCHITECTURE & INTERFACE DIAGRAMS

3.1 Terminal Block Interface Layout

The Jasmine JSH-HSW-01-N is equipped with a **12-pin green terminal block** on its main face, divided into **4 dedicated channels** with 3 terminal pins per channel.

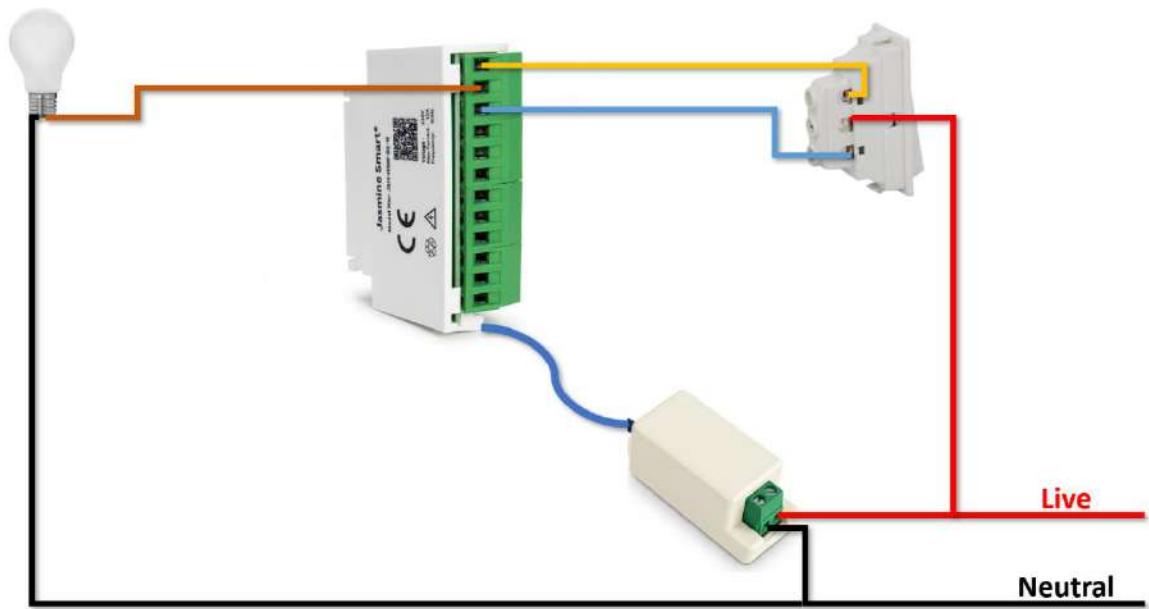

Diagram of the Circuit for 1st Channel

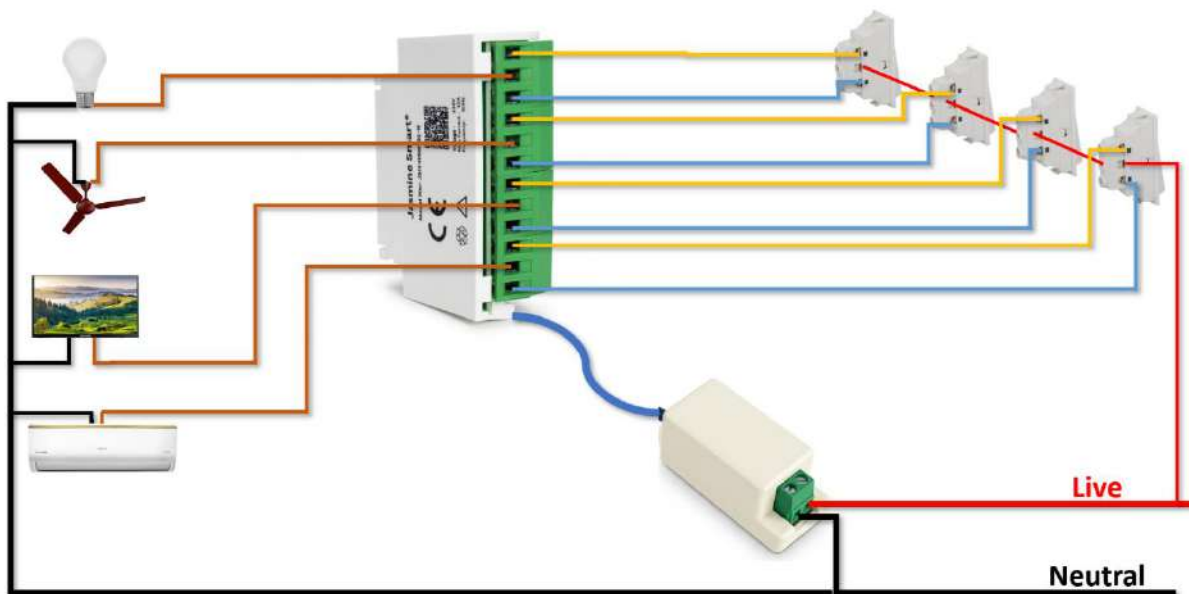

Diagram of the Fully Connected Circuit

Jasmine JSH-HSW-01-N



===== JSH-HSW-01-N =====

[PIN 1] ---- Channel 1 - TOP (To 2-Way Switch Top)

[PIN 2] ---- Channel 1 - MIDDLE (To Appliance Load)

[PIN 3] ---- Channel 1 - BOTTOM (To 2-Way Switch Bottom)

[PIN 4] ---- Channel 2 - TOP (To 2-Way Switch Top)

[PIN 5] ---- Channel 2 - MIDDLE (To Appliance Load)

[PIN 6] ---- Channel 2 - BOTTOM (To 2-Way Switch Bottom)

[PIN 7] ---- Channel 3 - TOP (To 2-Way Switch Top)

[PIN 8] ---- Channel 3 - MIDDLE (To Appliance Load)

[PIN 9] ---- Channel 3 - BOTTOM (To 2-Way Switch Bottom)

[PIN 10] ---- Channel 4 - TOP (To 2-Way Switch Top)

[PIN 11] ---- Channel 4 - MIDDLE (To Appliance Load)

[PIN 12] ---- Channel 4 - BOTTOM (To 2-Way Switch Bottom)

=====

[BOTTOM RECEPTACLE]

^

| (Plug-and-Play Quick Connector)

[ADAPTER OUTPUT TAIL]

3.2 Power Adapter Interface



- **Adapter Input Terminal block:** 2-pin screw-type green terminal block (labeled **Live** and **Neutral**).
- **Adapter Output Cable:** Integrated low-voltage DC power tail wire terminated with a keyed, quick-release connector designed to lock into the **Bottom Receptacle** of the primary Smart Switch Module.

4. PRE-INSTALLATION CHECKLIST

Before commencing installation, ensure you have the following tools and materials:

1. **Insulated Screwdrivers** (Flathead and Philips size #1 and #2)
2. **Non-Contact AC Voltage Tester**
3. **Wire Strippers** / Utility cutters
4. **Solid/Stranded Copper Wire** (Recommended: 1.5 mm²/ 16 AWG for low-power lighting, 2.5 mm²/ 14 AWG for high-power circuits)
5. **Electrical Junction Box** matching modular depth requirements

5. STEP-BY-STEP ELECTRICAL WIRING PROCEDURES

PHASE A: POWER ADAPTER INTEGRATION

1. Terminate the main **AC Live Line** (typically Red/Brown) into the input terminal labeled **Live** on the Power Adapter Module.
2. Terminate the main **AC Neutral Line** (typically Black/Blue) into the input terminal labeled **Neutral** on the Power Adapter Module.
3. Locate the integrated tail cable extending from the Power Adapter Module.
4. Insert the male connector plug of the tail cable directly into the dedicated female receiving socket located at the **bottom** of the primary JSH-HSW-01-N Smart Switch Module until it clicks firmly into place.

PHASE B: PHYSICAL 2-WAY SWITCH LOOP WIRING

Each physical switch must be a standard **3-terminal 2-way toggle switch** (comprising a Top terminal, a Middle/Common terminal, and a Bottom terminal).

1. Connect the main **Live Line** directly to the **Middle (Common) terminal** of *all four* physical wall switches.
2. For each channel, wire the remaining terminals to the Jasmine Module according to the following matrix:

Channel Number	Primary Switch Name	Connection from Switch "Top"	Connection from Switch "Bottom"
Channel 1	Switch 1 (Load 1 Control)	Connects to Pin 1 (Top)	Connects to Pin 3 (Bottom)
Channel 2	Switch 2 (Load 2 Control)	Connects to Pin 4 (Top)	Connects to Pin 6 (Bottom)
Channel 3	Switch 3 (Load 3 Control)	Connects to Pin 7 (Top)	Connects to Pin 9 (Bottom)
Channel 4	Switch 4 (Load 4 Control)	Connects to Pin 10 (Top)	Connects to Pin 12 (Bottom)

PHASE C: LOAD / APPLIANCE TERMINATION

For safety, all connected appliances must have their Neutral paths properly grounded to the main system neutral, leaving only the Live path switched through the JSH-HSW-01-N.

1. Connect the **switched Live wire** of each appliance to the corresponding channel's **Middle Pin** on the 12-pin terminal block:
 - **Appliance 1 Switched Live:** Connects to **Pin 2**
 - **Appliance 2 Switched Live:** Connects to **Pin 5**
 - **Appliance 3 Switched Live:** Connects to **Pin 8**
 - **Appliance 4 Switched Live:** Connects to **Pin 11**
2. Connect all **Neutral return wires** from the four appliances directly to the main system **Neutral Line** (or common Neutral busbar in the distribution box).

5. SYSTEM COMMISSIONING & TESTING

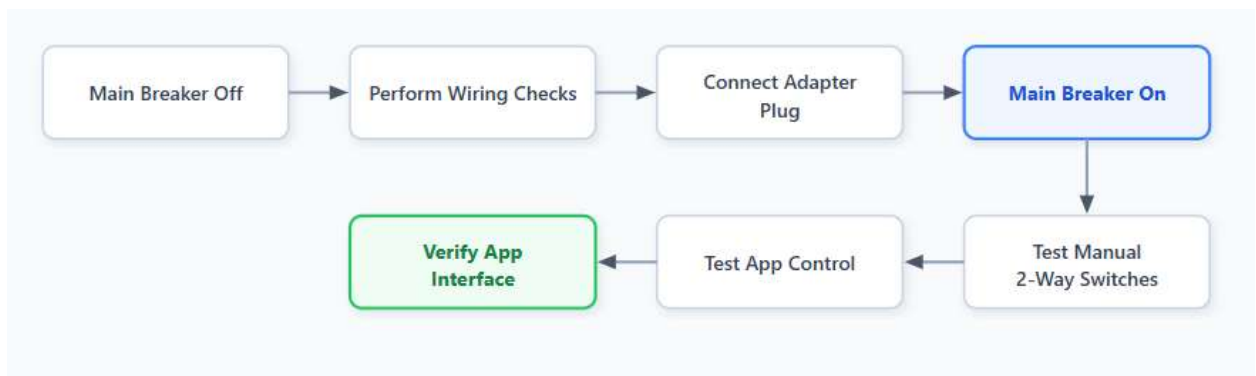

1. **Verify Wire Retention:** Gently pull on each wire to confirm they are clamped securely in their respective terminal blocks. Ensure no stray wire strands are exposed outside the green terminals.
2. **Mount Hardware:** Carefully route and tuck the wires, power adapter module, and the JSH-HSW-01-N module inside the wall junction box. Securely screw the physical faceplate over the wall box.
3. **Power On:** Switch **ON** the main circuit breaker.
4. **Manual Switch Test:** Toggle each of the four physical wall switches on and off. Verify that each switch controls its corresponding appliance immediately and without delay.
5. **Smart Control Syncing:** Open the Jasmine Smart mobile app, put the JSH-HSW-01-N module into pairing mode, and follow the on-screen instructions to register all 4 channels to your home automation environment.

SYSTEM TROUBLESHOOTING

Symptom	Probable Cause	Corrective Action
Device remains completely unpowered; LEDs are dark.	Loose connection at the main power supply or unseated adapter cable.	<ol style="list-style-type: none">1. Turn off main breaker.2. Confirm AC Live/Neutral wires are securely screwed into the Power Adapter input.3. Verify that the quick-connector tail is fully clicked into the bottom of the JSH-HSW-01-N.
Physical switch is toggled but the appliance does not respond.	Mismatched or swapped wiring between the Top, Middle, and Bottom terminals of the 2-way switch.	<ol style="list-style-type: none">1. Ensure the main Live feed is connected to the Middle (Common) terminal of the switch.2. Confirm the Switch Top and Bottom wires map exactly to the Top and Bottom Pins of that channel's terminal block.
App controls the appliance, but physical switch has no effect.	Broken loop on the 2-way toggle lines.	<p>Check integrity of the control loop wires connected to the Top and Bottom terminals of the respective channel.</p> <ol style="list-style-type: none">1. Ensure the load current does not exceed system specification ratings.
Appliance flickers or behaves erratically.	Overloaded channel or loose neutral wire at load.	<ol style="list-style-type: none">2. Verify the appliance's Neutral connection to the common Neutral bus.

For Mobile Application search Jasmine Smart or scan the QR code located on the side panel of the JSH-HSW-01-N module casing.